

list	revisions	REMARK	DWN	APVD	DATE

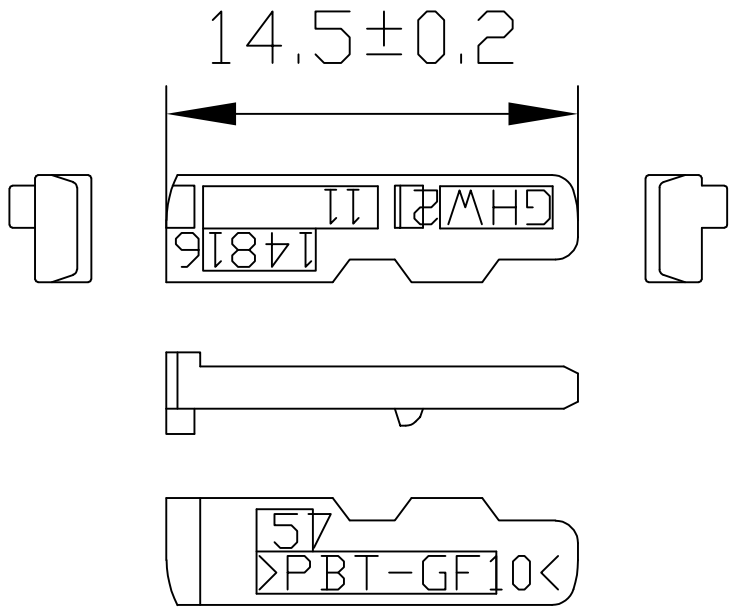
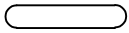

NOTE:

1. The font height is 0.1mm
2. There is no bad injection molding, crush, deformation and so on on the surface of the product.
3.  QC Control
4. OEM: 14816.660.636

XF				item type	SECONDARY LOCK	Client	
				name	XF14816.660.636		
设计	赖春裕	date	2019.9.02	color	Blue	page	1
校对	杨建刚	date	2019.9.02	material	PBT+GF	scale	
核准	张亦翔	date	2019.9.03	weight		version	2019.9
